



NORIMOS 4 – High Performance **PLC-based Alarm, Monitoring and Control System**

The system concept

The N4 is our alarm, monitoring and control system (AMCS) for highest demands in operating comfort, usability, flexibility and system availability. It is used to monitor and control ship technology, such as engines, generators, pumps, valves, ventilators or other auxiliary systems. The N4 is a PLC based AMCS with decentrally placed subsystems. Each subsystem is operating independently with a high performance I/O CPU master and its slave units and is connected to the other subsystems. The system can be easily adapted to customer requirements. With features like data logging, trend monitoring, alarm and event history and user right management, the system is ideally suitable for simple as well as sophisticated applications. Furthermore, the system can be easily extended with remote access for automatic and secure data transfer and storage to onshore data services for analysing purposes. The optional alarm extension indicates the system status at any place on board the ship. Therefore, different display versions for accommodation and bridge are available.

Visualisation for maximum flexibility

The NORIVIS 4 visualisation software makes system information available on the screen in an application-oriented and comfortable way on data viewing stations (PCs), on displays in the engine control room, office, on the bridge or any other location on the vessel.

Your benefits at a glance

- Decentral and modular PLC-based system for maximum flexibility and failsafe operation
- Robust, reliable and approved components
- Easily expandable for your application
- Easy-to-customise thanks to modular design
- Customer-specific mimics
- Integrated Webserver for remote access and secure data transfer
- Powerful alarm extension system
- Worldwide service
- Class approvals: ABS
BV, DNV-GL, LR (in preparation)



NORIMOS 4 system overview

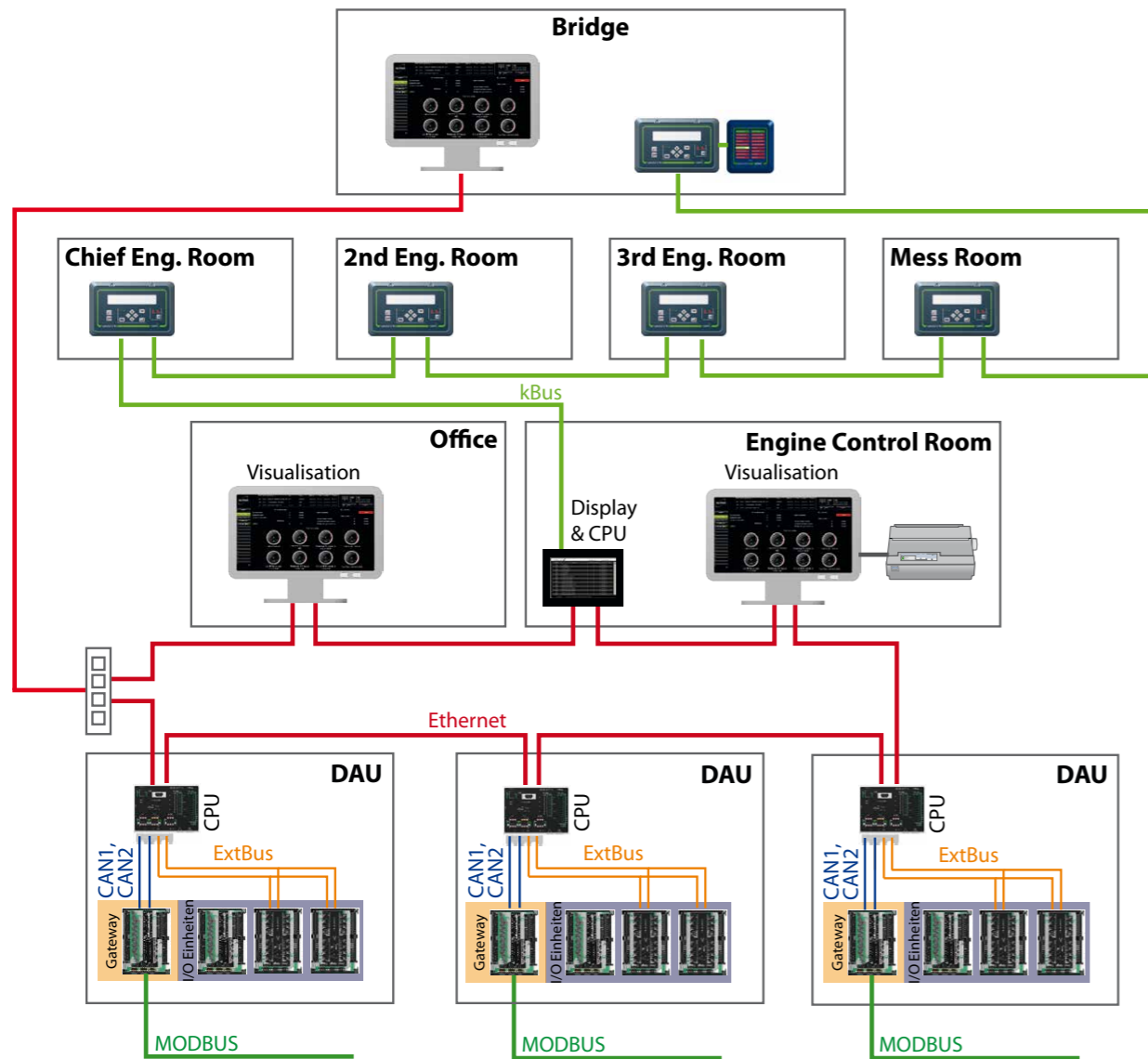

System structure with autarkic signal processing units

The system is based on decentral autarkic data acquisition units (DAUs). Each DAU contains a master CPU device and several slave I/O devices and operates as an independent subsystem. The whole data processing is done in the decentral DAUs.

System communication

The communication between the DAUs and the visualisation PC stations in the engine control room is realised via a ring Ethernet network. This guarantees maximum safety and system availability. The NORIS ExtBus is used for the communication between I/O slaves and the CPU master unit.

Furthermore, the system provides a MODBUS interface for interconnection with third party systems.

System extension

The system can be easily extended via Ethernet. Therefore, additional PCs and displays, e. g. for offices or cargo rooms and also printers for alarm printing can be connected. The system also offers an alarm extension panel for accommodation and an alarm display for the bridge, both equipped with CAN, Ethernet and RS-485 interface. Of course, the alarm extension can be adapted to the respective class rules which fulfil the requirement for unmanned machinery space (UMS).

I/O units for signal processing

The CPU master comes with a freely programmable PLC in compliance with IEC 61131 (e. g. ST, IL, FBD, CFC etc.) and a powerful 32-bit processor with multitasking support to execute multiple programs at the same time. The signal processing of the I/O slave unit involves binary channels, 4...20 mA, 0...20 mA, 0...5 V, 0...10 V, Pt100/Pt1000, thermocouples and speed sensors. Of course, all inputs are galvanically isolated to the operating voltage and earth fault monitored.

NORIMOS 4 system features

Suitable for your application

- Measurement data acquisition and data recording
- Engine alarm and monitoring
- Engine start/stop
- Control and monitoring of bilge and ballast system
- Control of other auxiliary systems (pumps, valves, ventilators, etc.)
- Power management

Visualisation

- Modern and uniform look & feel
- Easy-to-customise graphical colour mimic display
- Intuitive, clear and easy to understand GUI
- Measuring parameter list, alarm list, alarm history, event history and trend tables
- Graphical indication with gauges and bar graphics
- Remote access

Alarm extension and duty assignment

- Alarm extension display for accommodation and bridge
- Duty assignment and duty takeover for unmanned machinery space
- Engineer call function
- Connection of external fire alarm system

Other System Features

- Easy to configure via free programmable PLC in compliance with IEC 61131 (e. g. ST, IL, FBD, CFC etc.)
- Remote access for data transfer and storage (e. g. via vessel network skyDSL, GSM, GPRS)
- Data logging, automatic storage of alarm and event history, alarm printing
- Different user access levels for standard users and administration
- Easy maintenance and update via USB

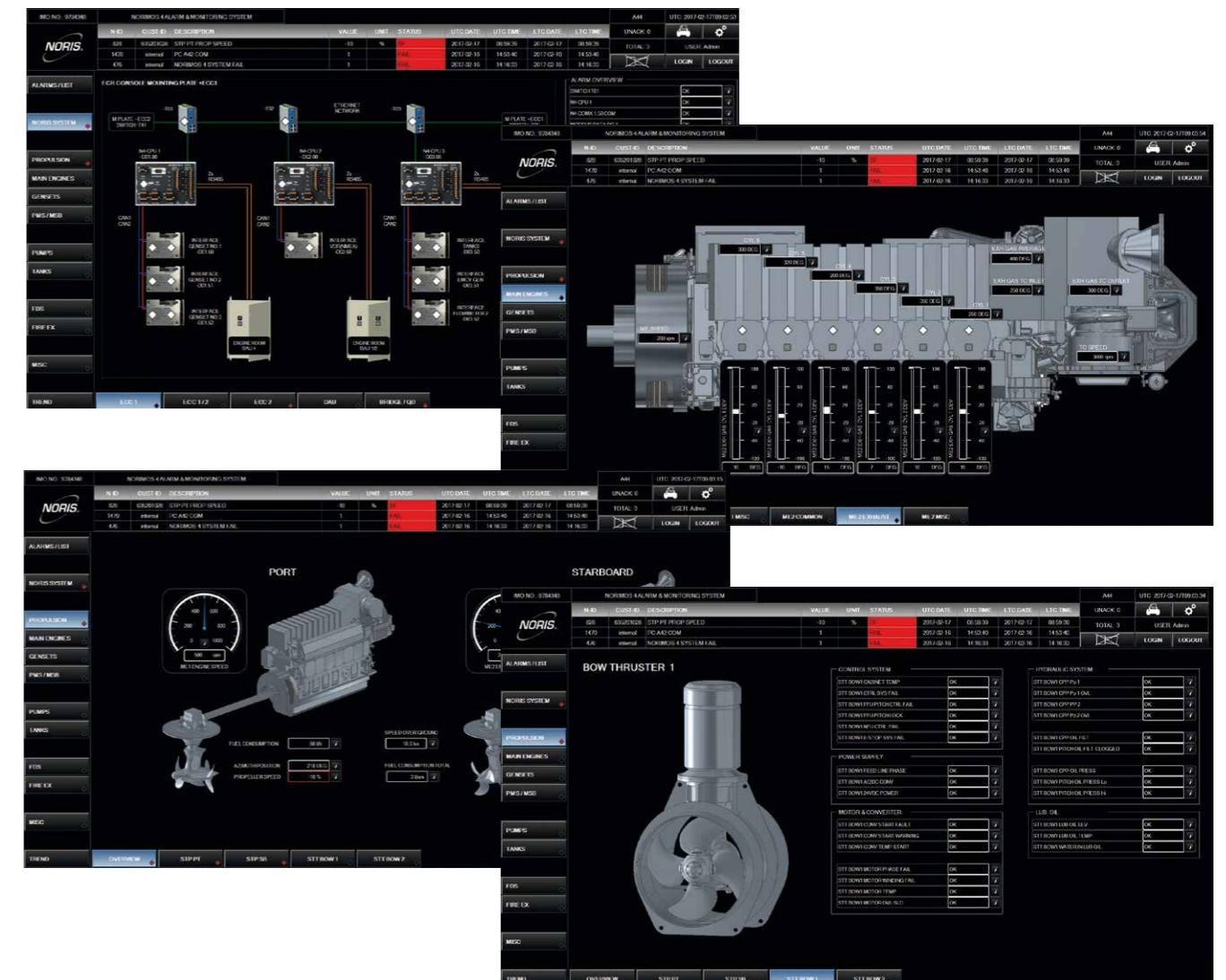

NORINET for secure data transfer and remote access

System maintenance is essential in order to minimise service and repair costs and to keep all systems on board running. We have the right solution that avoids idle time in ports and enables us to react flexibly and fast. Remote access and the long time storage of engine and monitoring system data are further essential factors concerning analysis and predictive maintenance. In times of skyDSL/GSM/GPRS the remote access is a useful feature to stay in touch with your vessel.

NORIS offers the appropriate infrastructure for all its systems. The data is stored on board into a ring buffer of an offshore data unit and is cyclically transferred via secure connection and HTTPS to the NORINET.

Your benefits at a glance

- Flexibility for the ship owner and his crew
- Enables system secure remote access
- Realtime access to monitoring system
- Optimises maintenance processes, and thus, ensures failsafe operation
- Easy system updates
- Enables data transfer for analysing purposes

NORINET Features

- Web access via secure connection and HTTPS
- Data access on historical logs
- Real-time access for limited tags (~ 50)
- Trend analyses
- Geo indication
- Alarm/Error message overview
- Reports generator (logs, trends, alarm lists)
- Multi user access to a webpage
- Dashboard for general information

Offshore Data Unit Features

- Data acquisition
- Data pre-analysing
- Data storage into ring buffer
- Cyclic data logging to portal

